

Electronic Overload Guard

FEATURES

- Redundant safeguarding system with two independent inputs for load cells
- Meets category 3 EN 13849-1:2008, PL d standard
- Load limiter featuring double security design
- Integrated alarm for load cell malfunction or power failure
- Mountable on DIN rail

OPTIONS

- Analog option

APPLICATIONS

- Off-highway vehicles
- Agricultural equipment
- Construction equipment
- Lifting machines
- Telescopic loaders

DESCRIPTION

The WG3 is specifically designed to prevent a weight bearing machine from exceeding its capacity. It can monitor and convert the outputs of up to four 350 Ω load cells and prevent their combined output from surpassing

the limit set. It boasts a redundant safeguarding system that allows the load cells to be connected as independent pairs. The WG3 also features an integrated alarm for detecting load cell malfunctions or power failure, and a 60°C operating temperature range

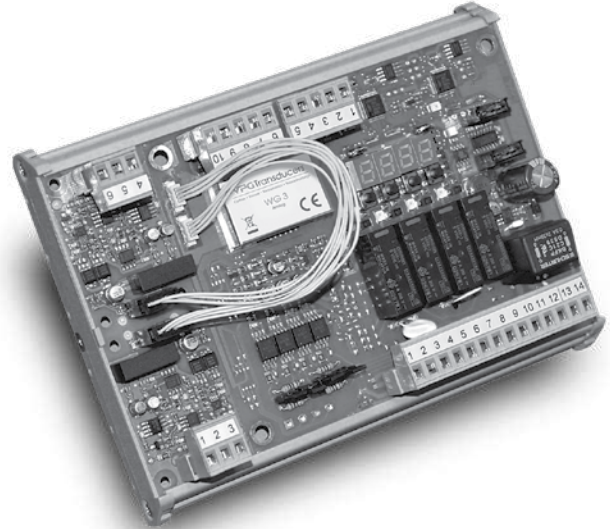

OUTLINE DIMENSIONS

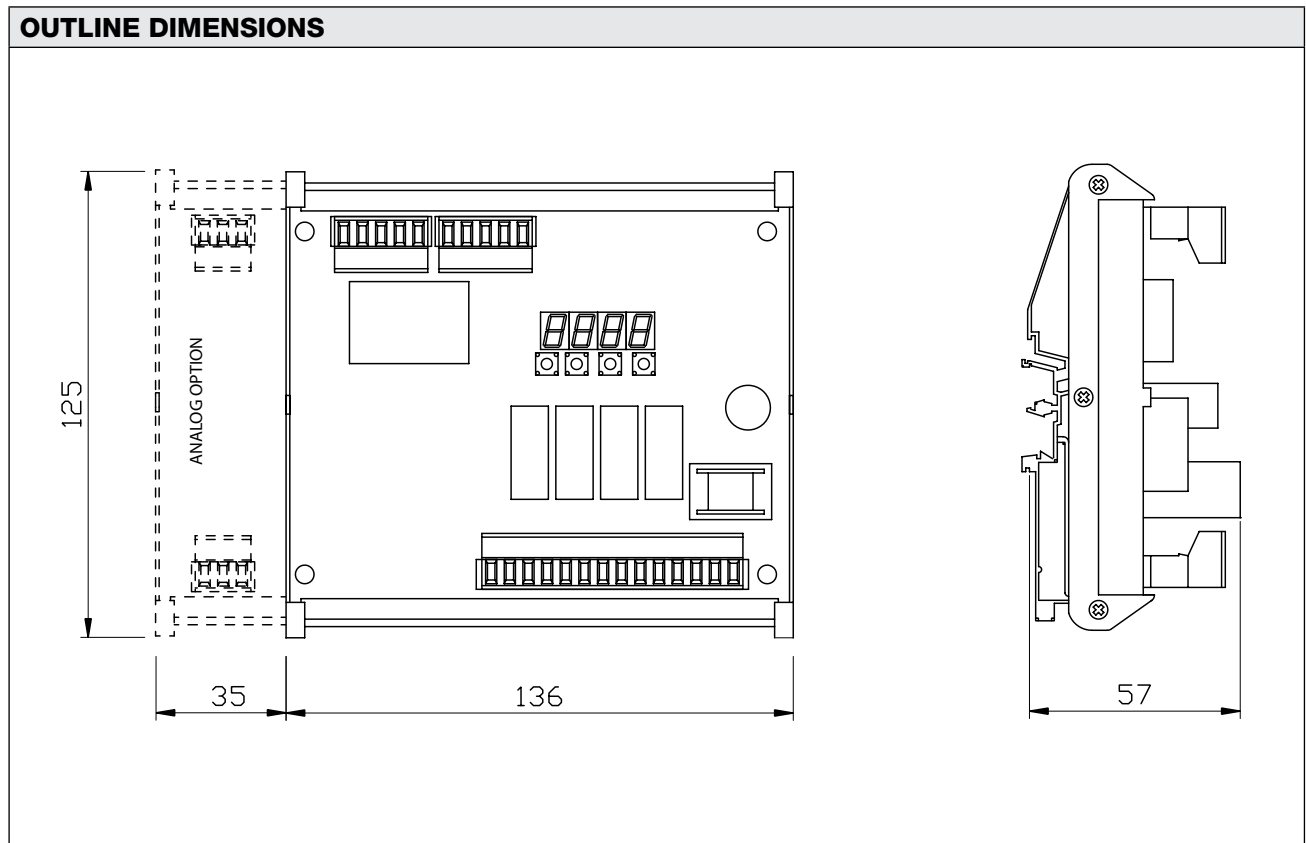

Electronic Overload Guard

WIRING DIAGRAM

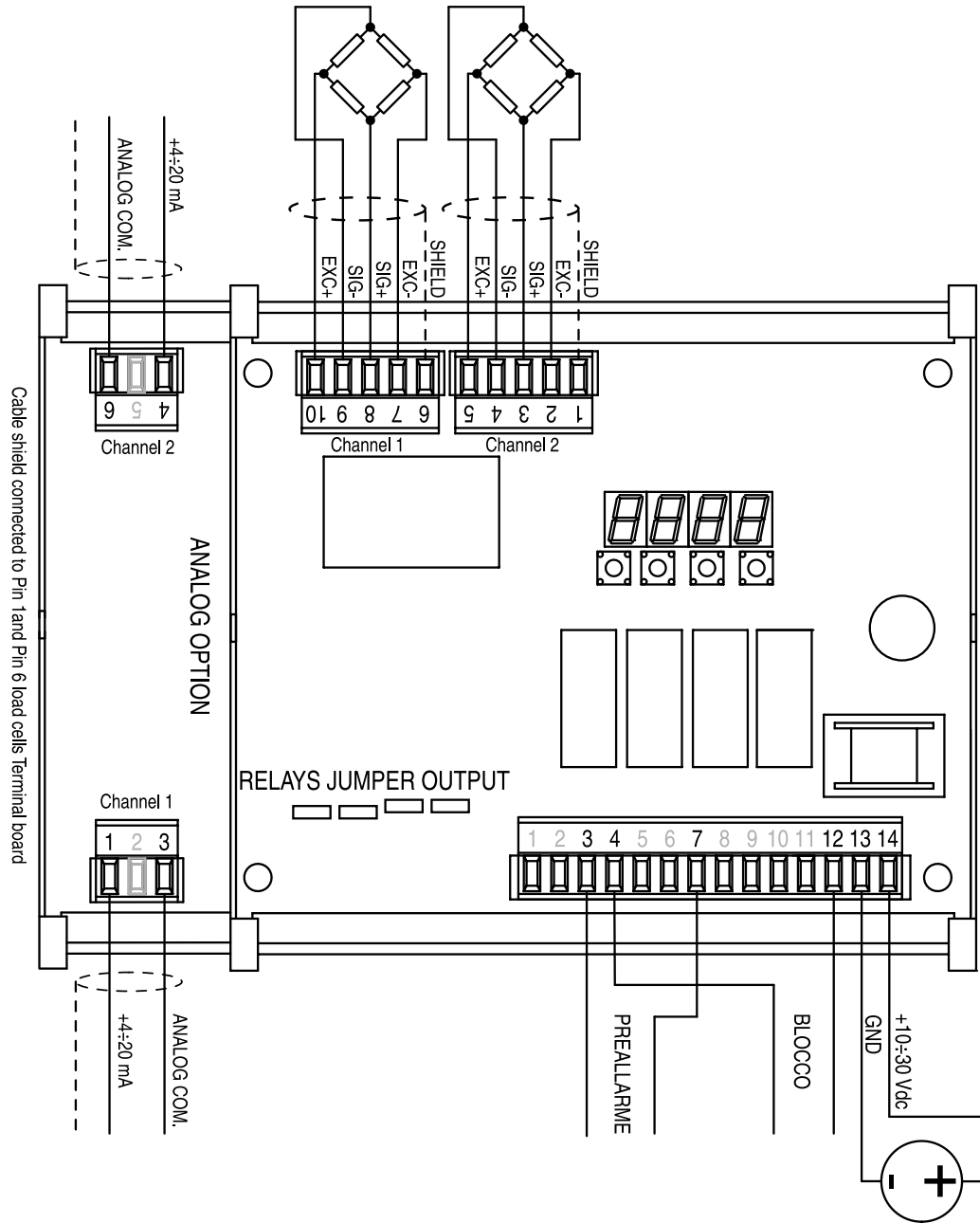

Electronic Overload Guard

SPECIFICATIONS**PERFORMANCE****Power Output**

10 to 30 VDC

Insulation

Class III

Measuring Range

-3.9 to +3.9 mV/V

Input Sensitivity0.02 μ V/division**Internal Resolution**

24 bit

Calibration Type

Digital, from the keyboard

Frequency Signal Updates

12 to 1000 Hz

Filter (Adjustable)

0.25 to 3 Hz

ENVIRONMENTS**Operating Temperature**

-10 to +50°C (max humidity before condensation 85%)

Storage Temperature

-20 to 60°C

ELECTRICAL**Maximum Power Consumption**

6 W

DISPLAY AND KEYBOARD**Display**

4 digit, 7 segment LED

Digit Height

7 mm

Keyboard

4 key mechanical keyboard

Functions Executable From Keyboard

Calibration of Zero and Full Scale values

INPUT AND OUTPUTS**Load Cell Inputs**4 at 350 Ω for both measuring channels**Logic Outputs Alarm**

4 relay outputs

Interruption Control for Load Cell Cable

Indication on the display and via relay

Optional Analogue Output

4 to 20 mA (1 output per channel)

Resolution

16 bit

Linearity

<0.03% of full scale

Impedance300 Ω **ENCLOSURES****Dimensions**

136 x 125 x 57 mm L x H x D;

171 x 125 x 57 mm L x H x D with analog option

Mounting

DIN rail mount

Electrical Connections

5.08 mm terminal screw blocks

APPROVALS**EN**

EN 61000-6-2; EN 61000-6-3 EMC to EN 61010-1 for electrical safety;

EN 13849-1 parts of control systems related to safety

Electronic Overload Guard

ORDERING INFORMATION FOR WG3

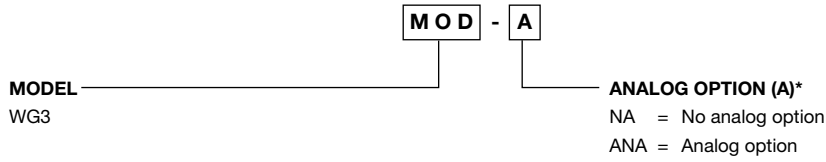

Example Completed Part Numbers:

WG3-ANA is the part number for a WG3 with an analog output.

WG3-NA is the part number for a WG3 with no analog output.

***This is mandatory: customers must select an output option.**

All specifications subject to change without notice. For inquiries within Italy please contact the VPG Transducers Marketing Department directly using the email address vpgt.marketing@vpgsensors.com.



Disclaimer

ALL PRODUCTS, PRODUCT SPECIFICATIONS AND DATA ARE SUBJECT TO CHANGE WITHOUT NOTICE.

Vishay Precision Group, Inc., its affiliates, agents, and employees, and all persons acting on its or their behalf (collectively, "VPG"), disclaim any and all liability for any errors, inaccuracies or incompleteness contained herein or in any other disclosure relating to any product.

The product specifications do not expand or otherwise modify VPG's terms and conditions of purchase, including but not limited to, the warranty expressed therein.

VPG makes no warranty, representation or guarantee other than as set forth in the terms and conditions of purchase. **To the maximum extent permitted by applicable law, VPG disclaims (i) any and all liability arising out of the application or use of any product, (ii) any and all liability, including without limitation special, consequential or incidental damages, and (iii) any and all implied warranties, including warranties of fitness for particular purpose, non-infringement and merchantability.**

Information provided in datasheets and/or specifications may vary from actual results in different applications and performance may vary over time. Statements regarding the suitability of products for certain types of applications are based on VPG's knowledge of typical requirements that are often placed on VPG products. It is the customer's responsibility to validate that a particular product with the properties described in the product specification is suitable for use in a particular application. You should ensure you have the current version of the relevant information by contacting VPG prior to performing installation or use of the product, such as on our website at vpgsensors.com.

No license, express, implied, or otherwise, to any intellectual property rights is granted by this document, or by any conduct of VPG.

The products shown herein are not designed for use in life-saving or life-sustaining applications unless otherwise expressly indicated. Customers using or selling VPG products not expressly indicated for use in such applications do so entirely at their own risk and agree to fully indemnify VPG for any damages arising or resulting from such use or sale. Please contact authorized VPG personnel to obtain written terms and conditions regarding products designed for such applications.

Product names and markings noted herein may be trademarks of their respective owners.

Copyright Vishay Precision Group, Inc., 2014. All rights reserved.