

# Operating Instructions for Rotating Vane Flow Meter

## Model: DRH-...

Typ: DRH-...E/...G



Typ: DRH-...L



Typ: DRH-...C



## 1. Contents

---

1. Contents.....	2
2. Note .....	3
3. Instrument Inspection.....	3
4. Regulation Use .....	3
5. Operating Principle.....	4
6. Mechanical Connection.....	4
6.1. Check service conditions: .....	4
6.2. Installation.....	4
7. Electrical Connection .....	5
7.1. General.....	5
7.2. Output electronics: Frequency output (..F300;..F320, ..F340) .....	5
7.3. Output electronics: Analogue output (..L303, ..L342, ..L343, ..L442)....	6
7.4. Cable outlet with M12x1 angle plug electronic options F3x and L3x....	7
7.5. Compact electronics: (..C30R, ..C30M, ..C34P, ..C34N) .....	8
8. Commissioning – Output electronics.....	9
8.1. General.....	9
8.2. Setting - compact electronics.....	9
9. Maintenance .....	9
10. Technical Information.....	10
10.1. Sensor Data.....	10
10.2. Output electronics.....	11
11. Order Codes .....	13
12. Dimensions .....	14
13. EU Declaration of Conformance .....	15
14. UK Declaration of Conformity.....	16

### Manufactured and sold by:

Kobold Messring GmbH  
Nordring 22-24  
D-65719 Hofheim/Germany  
Tel.: +49(0)6192-2990  
Fax: +49(0)6192-23398  
E-mail: info.de@kobold.com  
Internet: www.kobold.com

---

## 2. Note

---

Please read these operating instructions before unpacking and putting the unit into operation. Follow the instructions precisely as described herein.

The instruction manuals on our website [www.kobold.com](http://www.kobold.com) are always for currently manufactured version of our products. Due to technical changes, the instruction manuals available online may not always correspond to the product version you have purchased. If you need an instruction manual that corresponds to the purchased product version, you can request it from us free of charge by email ([info.de@kobold.com](mailto:info.de@kobold.com)) in PDF format, specifying the relevant invoice number and serial number. If you wish, the operating instructions can also be sent to you by post in paper form against an applicable postage fee.

The devices are only to be used, maintained and serviced by persons familiar with these operating instructions and in accordance with local regulations applying to Health & Safety and prevention of accidents.

When used in machinery, the flow meter should only be placed in operation if the machine in use complies with the EEC machinery guidelines.

### **According to PED guideline 2014/68/EU**

No CE marking, see Article 4, Section 3 "Sound engineering practice",  
Guideline 2014/68/EU

Diagram 8, Piping systems, Group 1 Hazardous fluids

---

## 3. Instrument Inspection

---

Instruments are inspected before shipping and sent away in perfect condition. Should damage to a device be visible, we recommend a thorough inspection of the delivery packaging. In case of damage, please inform your parcel service/forwarding agent immediately, since they are responsible for damages during transit.

### **Scope of delivery:**

The standard delivery includes:

- Rotating Vane Flow Meter            model: DRH-...

---

## 4. Regulation Use

---

Any use of the DRH which exceeds the manufactures specification may invalidate its warranty. Therefore, any resulting damage is not the responsibility of the manufacturer. The user assumes all risk for such usage.

## 5. Operating Principle

---

KOBOLD Rotating Vane Flow Meters series DRH are used for measuring and monitoring low viscous liquids.

Series DRH flow meters are working according the well-known rotating vane principle. A magnet fitted in the vane and hermetically sealed from the medium transfers non-contacting the rotary motion to a Hall-effect sensor mounted in the housing. The sensor converts the rotary motion which is proportional to the flow to a frequency signal. A series-connected electronics unit converts the signal to an analogue output, limit contacts or display.

These devices can be adapted to prevailing plant conditions with the 360° rotatable screw connections.

## 6. Mechanical Connection

---

### 6.1. Check service conditions:

- Flow rate
- Maximum operating pressures
- Maximum operating temperature



---

**Attention! Overage can cause damage to bearings and cause major measuring errors.**

---

### 6.2. Installation

- It must be ensured that the instrument housing is continuously filled with the flow medium, especially for flows from top to bottom. No straight lengths are necessary at inlet and outlet connections.
- Check that flow is in the direction of the arrow on the front of the unit, and that the face of the unit is aligned in the vertical plane (axle in horizontal plane)
- Avoid pressure and tensile loads  
Mechanically secure the inlet and outlet lines 50 mm from the connection
- Check connections for leaks.

---

## 7. Electrical Connection

---

### 7.1. General



---

**Attention! Make sure that the voltages in your plant correspond with the flow meter voltages.**

---

- Make sure that all electrical supply lines are de-energised.
- Connect supply voltage and output signal to the plug connector pins as shown below.
- We recommend a power supply cable with diameter 0.25 mm<sup>2</sup>.



---

**Attention! The instrument electronics may be damaged if the cable connections are assigned incorrectly.**

---

### 7.2. Output electronics: Frequency output (..F300;..F320, ..F340)

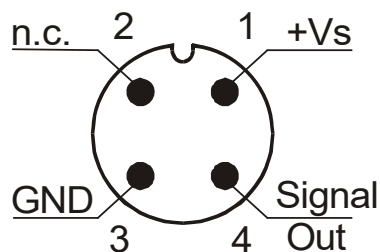

## 7.3. Output electronics: Analogue output (..L303, ..L342, ..L343, ..L442)

### 3-wire (..L303, ..L343)

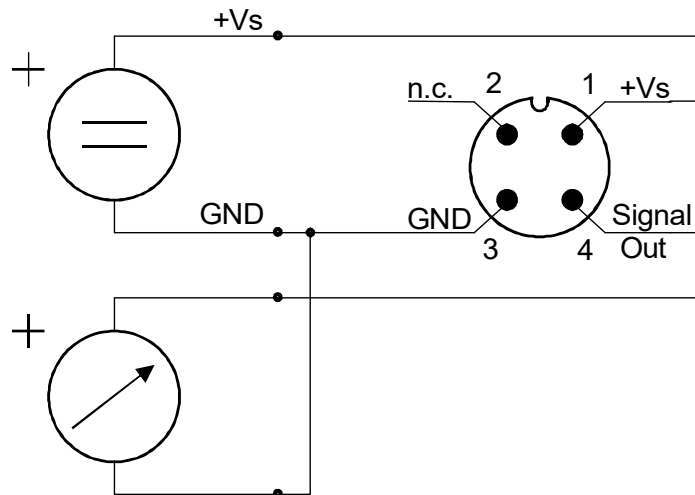

### 2-wire (..L342)

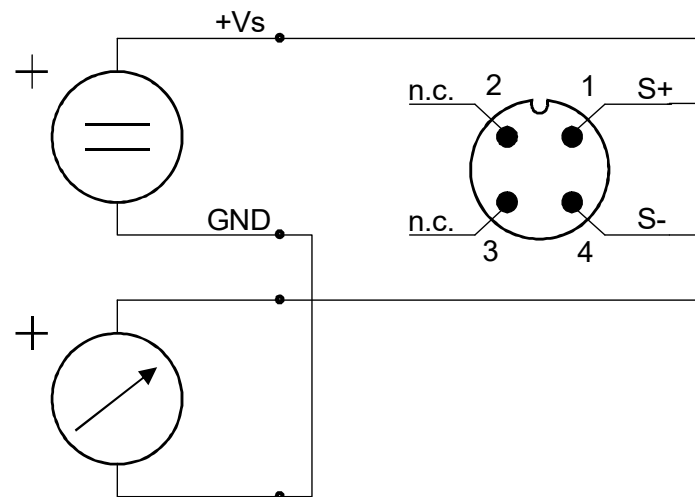

2-wire, DIN plug connector (..L442)

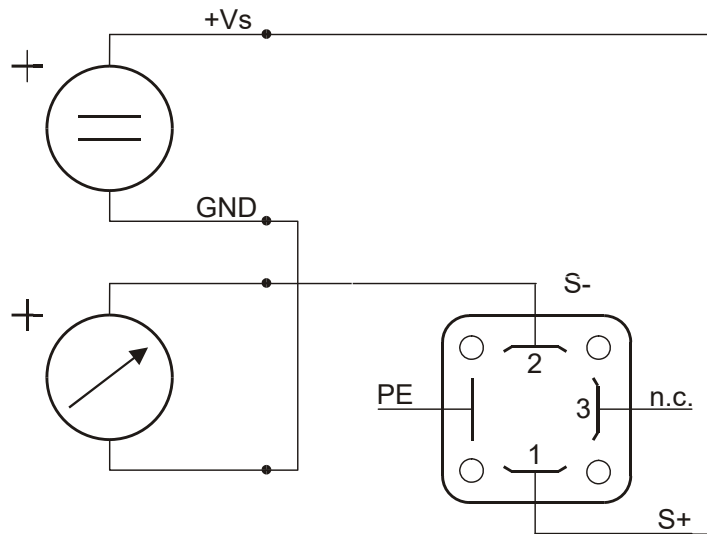

7.4. Cable outlet with M12x1 angle plug electronic options F3x and L3x

When using a pre-assembled M12x1 connection cable with angled plug, the cable outlet is always aligned opposite to the flow direction.

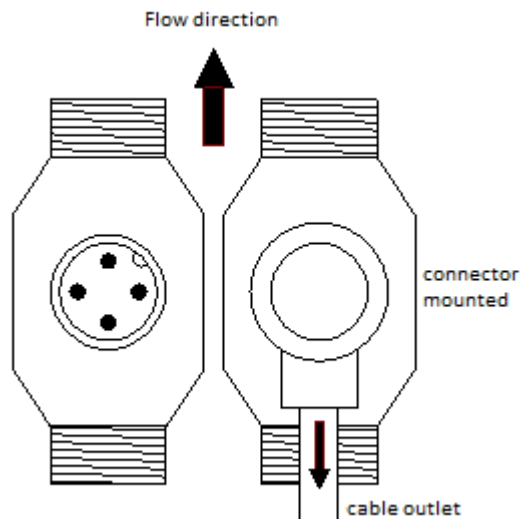

## 7.5. Compact electronics: (..C30R, ..C30M, ..C34P, ..C34N)

### 7.5.1. General



**Attention! Make sure that the voltages in your plant correspond with the flow meter voltages.**

- Make sure that all electrical supply lines are de-energised.
- Connect supply voltage and output signal to the plug connector pins as shown below.
- We recommend a power supply cable with diameter 0.25 mm<sup>2</sup>.



**Attention! The instrument electronics may be damaged if the cable connections are assigned incorrectly.**

### 7.5.2. Compact electronics: (..C30R, ..C30M)

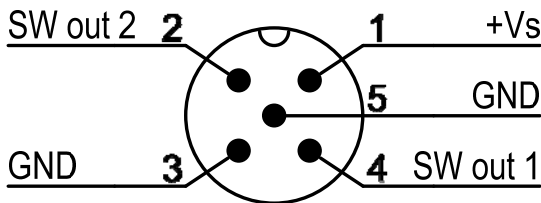

### 7.5.3. Compact electronics: (..C34P, ..C34N)

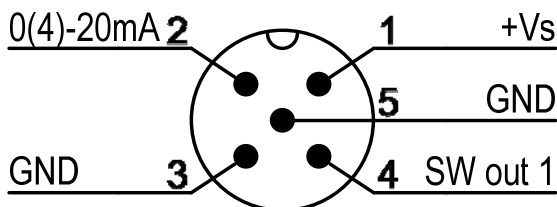

The clamps 3 and 5 are short-circuited and can therefore be used optional for the output signal or power supply.



## **8. Commissioning – Output electronics**

---

### **8.1. General**

The measuring instruments are preset and are ready for operation after electrical connection.

### **8.2. Setting - compact electronics**

**See  
Operating instructions supplement  
for compact electronics with frequency output**

## **9. Maintenance**

---

If the medium to be measured is clean, the Model DRH is virtually maintenance-free. It is particularly important to guard against contamination by ferritic (iron metal) contaminants. These can be eliminated by using e.g. the KOBOLD magnetic filter, model MFR.

However, if the sensor must be cleaned, it can be opened to gain access to the internal parts. Make sure that the sensor and, especially, the blades are not damaged during this procedure. When re-assembling, be certain that the vane is carefully positioned and oriented correctly.

Work on the sensor and electronics should only be carried out by the manufacturer, otherwise the guarantee is nullified.

## 10. Technical Information

### 10.1. Sensor Data

Material combinations:	see order details
Max. operating pressure:	see order details
Max. temperature:	see order details
Linearity:	±2.5 % f. s. ±5% f. s. (DRH-...F300)
Electrical connection:	plug connector DIN 43 650, plug connector M12x1, cable
Pressure loss:	max. 1 bar at max. range
Protection:	IP 65

#### Material combinations (Please enter order code instead of X "model")

Device parts	Order code: 1	Order code: 2	Order code: 4	Order code: 5	Order code: 7	Order code: 8	Order code: 9
<b>Housing</b>	Brass, nickel-plated	Brass, nickel-plated	1.4404	1.4404	POM	POM	PVDF
<b>Housing cover</b>	PMMA	Brass, nickel-plated	PMMA	1.4404	PMMA	POM	PVDF
<b>Gasket</b>	NBR	NBR	FPM	FPM	NBR	NBR	FPM
<b>Rotating vane</b>	PTFE	PTFE	PTFE	PTFE	PTFE	PTFE	PTFE
<b>Axle</b>	Ceramic	Ceramic	Ceramic	Ceramic	Ceramic	Ceramic	Ceramic
<b>Bearing</b>	PTFE	PTFE	PTFE	PTFE	PTFE	PTFE	PTFE
<b>p<sub>max</sub></b>	16 bar	100 bar	16 bar	100 bar	16 bar	16 bar	16 bar
<b>t<sub>max</sub></b>	80 °C	80 °C	80 °C	80 °C	80 °C	80 °C	80 °C
<b>Weight (3/8")</b>	850 g	1000 g	900 g	1050 g	250 g	250 g	300 g
<b>Weight (1")</b>	1600 g	2000 g	1600 g	2000 g	400 g	400 g	500 g

#### Weight

Weight (sensor)  
+Weight (electronics)

-----  
**Total weight**

#### Sensor weight

see material  
combination

#### Electronics weight

Frequency output: approx. 35 g  
 Analogue output (...L3...): approx. 35 g  
 Analogue output (...L4...): approx. 100 g  
 Compact electronics: approx. 650 g  
 Counter electronics: approx. 250 g  
 Dosing electronics: approx. 250 g

## 10.2. Output electronics

### Frequency output (...F300)\*

Power supply:	12-28 VDC
Power consumption:	10 mA
Pulse output:	PNP, open collector, max. 25 mA
Electrical connection:	plug connector M12x1

\* uncalibrated signal output

### Frequency output with frequency divider

Power supply:	24 VDC $\pm 20\%$
Power consumption:	15 mA
Pulse output:	PNP, open collector, max. 25 mA
Electrical connection:	plug connector M12x1
Division ratio:	1...1/128, factory setting

### Analogue output (plug-on display option)

Power supply:	24 VDC $\pm 20\%$
Output:	0-20 mA or 4-20 mA, 2-wire or 3-wire
Max. load:	500 $\Omega$ .
Electrical connection:	plug connector M12x1 or DIN 43 650
Option:	plug-on display (with plug connector DIN 43 650 and output 4-20 mA only), 2-wire

### Compact electronics

Display:	3-segment LED
Analogue output:	(0)4 -20 mA adjustable, max. 500 $\Omega$
Switching outputs:	1 (2) semiconductor PNP or NPN, factory set
Contact operation:	N/C / N/O contact frequency programmable
Setting:	with 2 buttons
Supply:	24 VDC $\pm 20\%$ , 3-wire technology, approx. 100 mA
Electrical connection:	plug connector M12x1

### DRH-...Exxx (Counter electronics)

Display:	LCD, 2x8 digits, illuminated Total, part and flow quantities, units selectable
Quantity meter:	8 digit
Analogue output:	(0)4...20 mA adjustable
Load:	max. 500 $\Omega$
Switching output:	2 relays, max. 30 V <sub>AC/DC</sub> /2 A/60 VA
Settings:	via 4 buttons
Functions:	Reset, MIN/MAX memory, flow monitor, monitoring for part and total quantity, language
Power supply:	24 VDC $\pm 20\%$ , 3-wire
Power consumption:	approx. 150 mA
Electrical connections:	cable connection or M12 plug

## **DRH-...Gxxx (Dosing electronics)**

Display:	LCD, 2x8 digits, illuminated dosing, total- and flow quantities, units selectable
Quantity meter:	8 digit
Dosage:	5-digit
Analogue output:	(0)4...20 mA adjustable
Load:	max. 500 $\Omega$
Switching output:	2 relays, max. 30 V <sub>AC/DC</sub> /2 A/60 VA
Settings:	via 4 buttons
Functions:	dosing (relay S2), start, stop, Reset, fine dosing, correction amount, flow switch, total quantity, language
Power supply:	24 VDC $\pm$ 20%, 3-wire
Power consumption:	approx. 150 mA
Electrical connections:	cable connection or M12 plug

## 11. Order Codes

Example: DRH- 1 1 05 N3 F300

Measuring range		Orifice diameter [mm]	Model	Connection		Evaluating electronics
L/min water	Frequency (Hz) at f.s. <sup>3)</sup>			Standard fem. thread	Special fem. thread	
0.2 - 0.8	63	1	DRH-1x05..	..G3..= G 3/8	..N3..= 3/8 NPT	<p><b>Frequency output</b>            ..F300= Frequency output, plug connector M12x1            ..F320= Frequency divider 1:2, plug connector M12x1            ..F340= Frequency divider 1:4, plug connector M12x1            ..F390= Frequency divider 1...<sup>1</sup>/128 plug connector M12x1</p> <p><b>Analogue output</b>            ..L303= 0 - 20 mA output, 3-wire, plug connector M12x1            ..L342= 4 - 20 mA output, 2-wire, plug connector M12x1            ..L343= 4 - 20 mA output, 3-wire, plug connector M12x1            ..L442= 4 - 20 mA output, 2-wire, plug connector DIN 43 650</p> <p><b>Compact electronics<sup>1)</sup></b>            ..C30R= LED display, 2x open collector, PNP, plug con. M12x1            ..C30M= LED display, 2x open collector, NPN, plug con. M12x1            ..C34P= LED display, 4 - 20 mA, 1x open coll., PNP, plug con. M12x1            ..C34N= LED display, 4 - 20 mA, 1x open coll., NPN, plug con. M12x1</p> <p><b>Counter electronics</b>            ..E14R= LCD, 0(4)-20 mA, 2x relay, 1.5 m cable            ..E34R= LCD, 0(4)-20 mA, 2x relay, M12 plug            ..E94R= LCD, 0(4)-20 mA, 2x relay, cable &gt;1.5 m<sup>2)</sup></p> <p><b>Dosing electronics</b>            ..G14R= LCD, 0(4)-20 mA, 2x relay, 1.5 m cable            ..G34R= LCD, 0(4)-20 mA, 2x relay, M12 plug            ..G94R= LCD, 0(4)-20 mA, 2x relay, cable &gt;1.5 m<sup>2)</sup></p>
0.2 - 2.0	50	2	DRH-1x10..	..G6..= G 1	..N6..= 1 NPT	
0.3 - 2.8	123	2	DRH-1x15..	..G3..= G 3/8	..N3..= 3/8 NPT	
0.25 - 5.0	78	3	DRH-1x20..	..G6..= G 1	..N6..= 1 NPT	
0.5 - 6.0	166	3	DRH-1x25..	..G3..= G 3/8	..N3..= 3/8 NPT	
0.5 - 15	145	5	DRH-1x30..	..G6..= G 1	..N6..= 1 NPT	
1.0 - 16	225	5	DRH-1x35..	..G3..= G 3/8	..N3..= 3/8 NPT	
1.0 - 26	240	7	DRH-1x40..	..G3..= G 3/8	..N3..= 3/8 NPT	
2.0 - 36	228	9	DRH-1x45..	..G6..= G 1	..N6..= 1 NPT	
2.5 - 50	220	10	DRH-1x50..	..G6..= G 1	..N6..= 1 NPT	

<sup>1)</sup> Please specify flow direction in writing.

<sup>2)</sup> Please specify cable length in writing.

<sup>3)</sup> Frequency deviation at F.S. (uncalibrated output): ±3%

## 12. Dimensions

Model: DRH-F3..., DRH-...L (with analogue output)

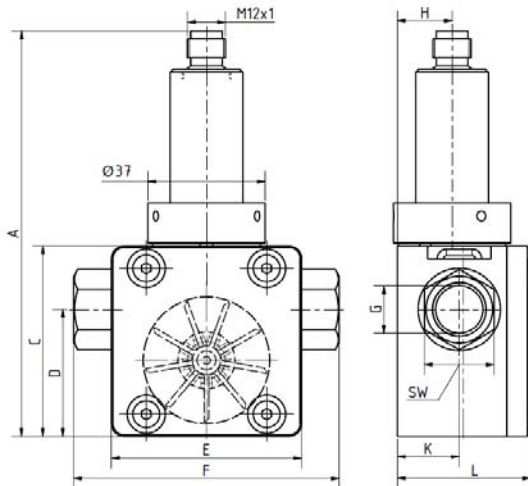

G	A	C	D	E	F	H	K	L	SW
3/8	128	60	40	60	84	17,5	19,5	42	22
1	138	70	42	70	110	22,5	22,5	53	41

Model: DRH-...L442 (with analogue output)

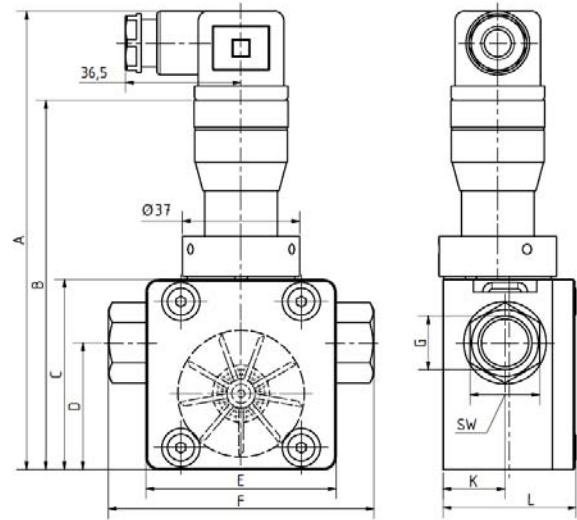

G	A	B	C	D	E	F	K	L	SW
3/8	145	117	60	40	60	84	19,5	42	22
1	155	127	70	42	70	110	22,5	53	41

Model: DRH-...C  
(with compact electronics)

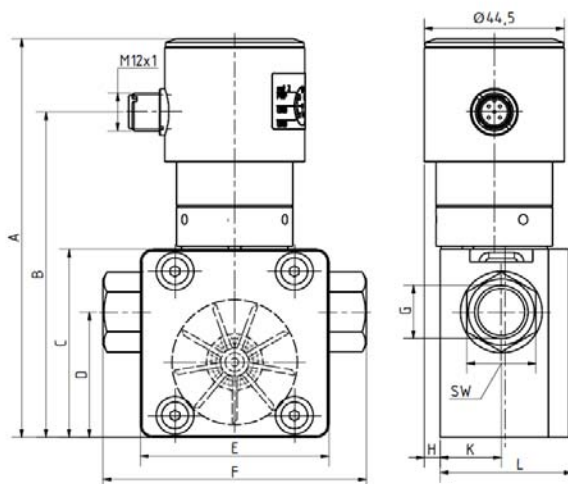

G	A	B	C	D	E	F	H	K	L	SW
3/8	128	104	60	40	60	84	5	19,5	42	22
1	138	114	70	42	70	110	-	22,5	53	41

Typ DRH-...E/G  
(counter electronics/dosing electronics)

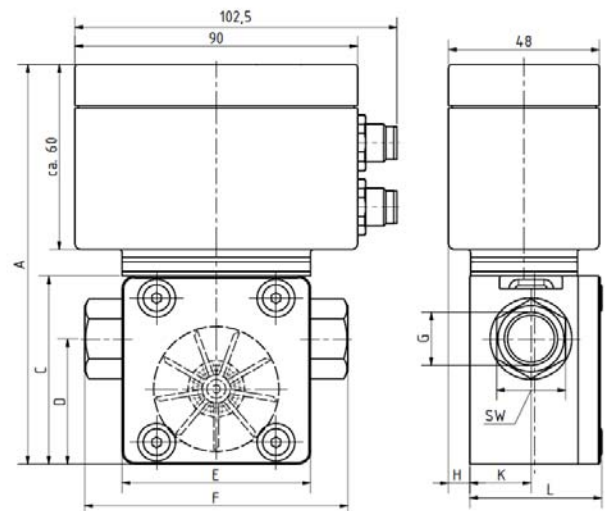

G	A	C	D	E	F	H	K	L	SW
3/8	128	60	40	60	84	7	19,5	42	22
1	138	70	42	70	110	2	22,5	53	41

## 13. EU Declaration of Conformance

---

We, KOBOLD-Messring GmbH, Hofheim-Ts, Germany, declare under our sole responsibility that the product:

**Rotating Vane Flow Meter**                      **model: DRH -...**

to which this declaration relates is in conformity with the standards noted below:

**EN 61000-6-4:2011**

Electromagnetic compatibility (EMC) - Part 6-4: Generic standards - Emission standard for industrial environments

**EN 61000-6-2:2006**

Electromagnetic compatibility (EMC) - Part 6-2: Generic standards - Immunity for industrial environments

**EN 61010-1:2011**

Safety requirements for electrical equipment for measurement, control and laboratory use - Part 1: General requirements

**EN 60529:2014**

Degrees of protection provided by enclosures (IP Code)

**EN IEC 63000:2018**

Technical documentation for the assessment of electrical and electronic products with respect to the restriction of hazardous substances

Also, the following EC guidelines are fulfilled:

**2014/30/EU**

**EMC Directive**

**2014/35/EU**

**Low Voltage Directive**

**2011/65/EU**

**RoHS (category 9)**

**2015/863/EU**

**Delegated Directive (RoHS III)**

Hofheim, 19 Jan. 2021



H. Peters  
General Manager



M. Wenzel  
Proxy Holder

## 14. UK Declaration of Conformity

---

We, KOBOLD Messring GmbH, Hofheim-Ts, Germany, declare under our sole responsibility that the product:

**Rotating Vane Flow Meter**                      **model: DRH -...**

to which this declaration relates is in conformity with the standards noted below:

**BS EN 61000-6-4:2007+A1:2011**

Electromagnetic compatibility (EMC). Generic standards. Emission standard for industrial environments

**BS EN 61000-6-2:2005**

Electromagnetic compatibility (EMC). Generic standards. Immunity for industrial environments

**BS EN 61010-1:2010**

Safety requirements for electrical equipment for measurement, control, and laboratory use. General requirements

**BS EN 60529:1992+A2:2013**

Degrees of protection provided by enclosures (IP Code)

**BS EN IEC 63000:2018**

Technical documentation for the assessment of electrical and electronic products with respect to the restriction of hazardous substances.

Also, the following UK guidelines are fulfilled:

**S.I. 2016/1091**

Electromagnetic Compatibility Regulations 2016

**S.I. 2016/1101**

Electrical Equipment (Safety) Regulations 2016

**S.I. 2012/3032**

The Restriction of the Use of Certain Hazardous Substances in Electrical and Electronic Equipment Regulations 2012



H. Peters  
General Manager



M. Wenzel  
Proxy Holder

Hofheim, 19 Jan. 2021