



## Insertion Paddle Wheel Flowmeter/Monitor

for low viscous liquids



measuring  
•  
monitoring  
•  
analysing

DOR

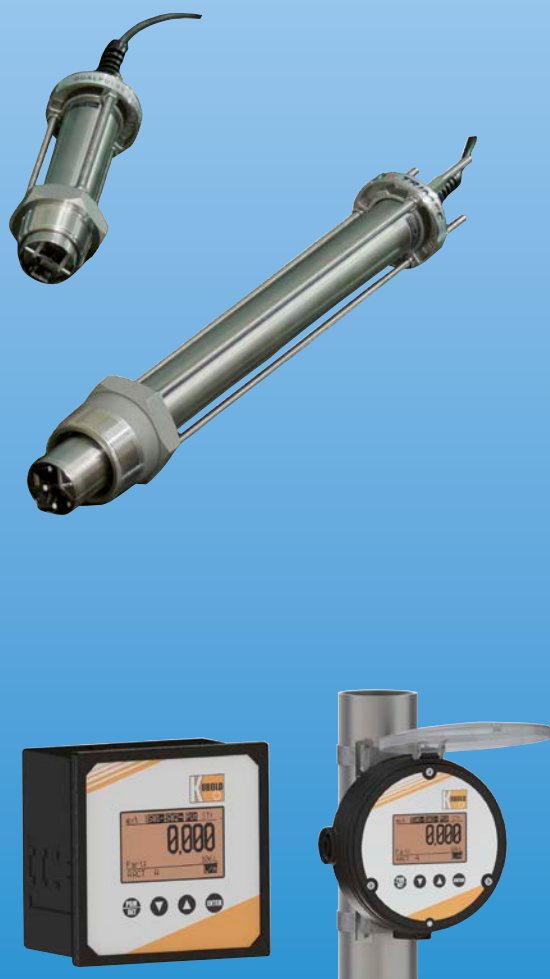

- Flow range:  
0.25 ... 6,300 l/s to 0.4 ... 49,000 l/s
- Flow velocity range: 0.3 - 10 m/s
- Viscosity range: low viscous
- $p_{\max}$ : 80 bar;  $t_{\max}$ : 150 °C
- Connection: R 1½, R 2 male,  
1½" NPT, 2" NPT male  
for pipe sizes: DN40 ... DN2500
- Linearity:  $\pm 1.5\%$  with well established  
flow profile
- Material: stainless steel
- Outputs: pulses, LCD display,  
batching, totalising

S4



KOBOLD companies worldwide:

AUSTRALIA, AUSTRIA, BELGIUM, BULGARIA, CANADA, CHINA, CZECHIA, EGYPT, FRANCE,  
GERMANY, GREAT BRITAIN, HUNGARY, INDIA, INDONESIA, ITALY, MALAYSIA, MEXICO,  
NETHERLANDS, PERU, POLAND, REPUBLIC OF KOREA, ROMANIA, RUSSIA, SPAIN,  
SWITZERLAND, THAILAND, TUNISIA, TURKEY, USA, VIETNAM

KOBOLD Messring GmbH  
Nordring 22-24  
D-65719 Hofheim/Ts.  
Head Office:  
+49(0)6192 299-0  
+49(0)6192 23398  
info.de@kobold.com  
www.kobold.com



### Description

The DOR series insertion paddle wheel flow sensor is a very cost effective instrument for accurately measuring the flow of water or water-like liquids in large pipes.

The sensor is inserted into the process piping via a thread-olet or half nipple fitting. Liquid flow through the pipe results in rotation of the affixed paddle wheel. The rotational speed of the paddle is proportional to the flow velocity, and therefore, proportional to the flowrate in the pipe.

The insertion type design provides a measuring technique that is much less expensive than full bore flowmeters, especially in larger pipe sizes. Insertion paddle wheel sensors are a robust measuring technology that boasts exceptional tolerance to dirt and solids.

The DOR series features an all 316L stainless steel body. The rotor is made of PVDF or PEEK, with a long-life, graphite/PTFE self-lubricating bearing. The DOR has an integral, precision insertion mechanism that allows the installer to insert the rotor to the precise depth in the pipe for optimal readings.

Outputs include NPN open collector frequency, and/or reed contact frequency. Optional indicators include battery powered totalisers, loop powered ratemeter/totalizers and batch controllers.

The DOR-5 is suitable for "hot tap" installation. With its symmetrical design the DOR may be used for bi-directional flow measurement.

### Applications

- HVAC: Hot and Chilled water, Fire system and thermal energy monitoring
- Municipal: Water distribution, water management and water treatment
- Irrigation: Water management
- Water treatment: Chlorination, de-salination and mechanical filtration plants, chemical injection systems
- Refineries: Primary flow additive injection, fire and cooling systems
- Power generation: Boiler feed water, steam condensate, process water and water balancing
- Chemical: Process & cooling tower water, chemical and water batching
- Others: Cement manufacturing, diesel fuel transferring, flow testing, fire truck and hydrant flow monitoring, food processing, pulp/paper, mining

### Technical Details

Velocity measuring range (linear):	0.3 ... 10 m/s equates to approx. 0.25 ... 49,000 l/s in DN 40 to DN 2500 pipes; 0.15 ... 10 m/s when using the linearisation function of electronic type ZOK-Z3 or ZOE
Linearity:	±1.5% with well est. flow profile
Repeatability:	±1% of f. s. at factory conditions and optimal straight runs
Max. pressure:	80 bar
Temperature range:	-40 ... +100 °C standard, see max. allowable medium temperature table for other options and restrictions

### Material

Body:	stainless steel 1.4404 (316L)
Rotor:	PVDF or PEEK (depending on model)
Rotor shaft:	stainless steel 1.4404 (316L)
Bearing:	graphite/PTFE
Seals:	FPM (standard): -15 ... +200 °C NBR (Nitril): -65 ... +125 °C

### Electronics

Output frequency at max. velocity:	220 ... 240 Hz (hall effect and voltage output), 73 ... 80 Hz (reed switch output)
Supply voltage:	see electrical output specifications and electronics comparison table
Electronic features:	see data sheet ZOK (only available as remote version)
Wiring (standard):	5 core, screened cable, length, 1 m (DOR-52), 1.5 m (DOR-42)
Transmission distance:	1000 meters maximum
Protection class:	IP68 (cable connection)
Straight piping requirement:	Minimum: 10xd (upstream), 5xd (downstream) Optimal: 25xd (upstream), 10xd (downstream)
Weight:	(approx., without electronics): 1.6 kg (DOR-4), 2.5 kg (DOR-5)



## Electrical Output Specifications

### Hall Effect Sensor Output (FX, NX, QX)

The **Hall Effect Sensor** is a high resolution solid state 3 wire device providing an unsourced, open collector, NPN transistor output. The term "unsourced" means that no voltage is applied to the output from within the flowmeter. It must be pulled to a 'high' or 'on' state by between 5 - 24V<sub>DC</sub> supplied from an external source, typically the receiving instrument. The pulse output between signal and -0V is a voltage square wave with the high level being the DC voltage available at the open collector and the low level being -0V.

The receiving instrument must incorporate a pull up resistor (typically greater than 10k $\Omega$  in most instruments) which ties the open collector to the available DC voltage level when the Hall sensor is not energized. When energized the open collector output is pulled to ground through the emitter (-0V).

Power supply: max. 5 - 24 V<sub>DC</sub>, max. 20 mA

### Voltage Pulse Output (FX)

A self generating 2 wire **voltage pulse output** with 1.5 V voltage spike of approximately 10 microseconds duration is generated with no dependence on rotor speed.

### Reed Switch Pulse Output (RX)

The **reed switch** output is a two wire normally open SPST voltage free contact ideal for installations without power or for use in hazardous area locations (simple apparatus) when Intrinsically Safe (I.S.) philosophy is adopted.

**Note:** when using the reed switch output the liquid temperature must not change at a rate greater than 10°C per minute. In general the reed switch life will exceed 2 billion actuations when switching less than 5V<sub>DC</sub> at 10mA.

Power supply: max. 30 V<sub>DC</sub>, 200 mA

### Quadrature Pulse Output (QX)

Two Hall Effect sensors arranged to give separate outputs out of phase with one another. The Quadrature output is typically suited to ensure output signal integrity or to measure bi-directional flow.

Power supply: max. 8 - 24 V<sub>DC</sub>, max. 20 mA

### NPN Inductive Pick-up (EX)

Inductive pick-up with non-magnetic rotor for applications with high ferrous content liquids.

Output is 3-wire NPN, 5-24 V<sub>DC</sub>, 20 mA max.



**Order Details** (Example: DOR-52 4 F R9 H5 00)

Model/ housing material	Rotor/shaft	Sealing material	Mechanical connection	Output/electrical connection	Electronics	Special op- tions
<b>DOR-42</b> (for pipe size 40 ... 900 mm) stainless steel	2 = PVDF/st. steel (max. 100 °C)	<b>F</b> = FPM (standard) <b>N</b> = NBR	<b>R8</b> = R 1½ male <b>R9</b> = R2 male <b>N8</b> = 1½" NPT male <b>N9</b> = 2" NPT male	<b>F0</b> = NPN OC + 1,5 V-pulse + standard cable length <sup>2)</sup> <b>F2</b> = NPN OC + 1,5 V-pulse + 10 m cable <b>F5</b> = NPN OC + 1,5 V-pulse + terminal box on stem kit <b>N5</b> <sup>1)</sup> = NPN OC + terminal box on stem kit + high temp. Sensor (+150 °C) <b>R0</b> = reed switch + standard cable length <sup>2)</sup> <b>R2</b> = reed switch + 10m cable <b>R5</b> = reed switch + terminal box on stem kit <b>Q0</b> = 2xNPN OC + standard cable length <sup>2)</sup> <b>Q2</b> = 2xNPN OC + 10m cable <b>Q5</b> = 2xNPN OC + terminal box on stem kit <b>XX</b> = special option (specified in clear text, consult factory)	<b>00</b> = frequency output only <b>XX</b> = special option (specified in clear text)	<b>none</b> = with- out <b>Y</b> = speci- fied in clear text
	<b>DOR-52</b> (for pipe size 50 ... 2,500 mm) stainless steel		4 = PEEK/st. steel (max. 150 °C) <b>X</b> = special (on request)	<b>R9</b> = R2 male <b>N9</b> = 2" NPT male		

<sup>1)</sup> Only possible with PEEK rotor and FPM seal  
<sup>2)</sup> Standard cable length DOR-42 = 1,5 m, DOR-52 = 1 m



**Process Temperature Limits with Rotor and Output Options\***

Rotor	Max. medium temperature
PVDF	100 °C
PEEK	200 °C
Output/Pick-up type	
F0, F2 R0, R2 Q0, Q2	100 °C
N5	150 °C
R5, F5, Q5	125 °C

\*Choose PEEK rotor for all options >100°C, keep temperature limits of sealing materials also in mind while selecting different options.

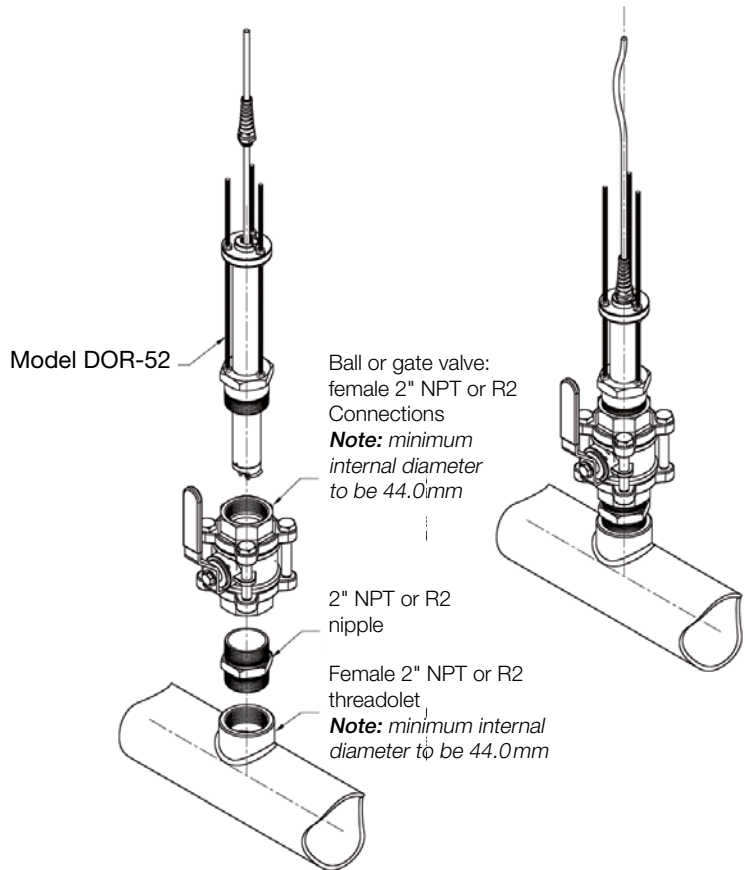

**Standard Installation**

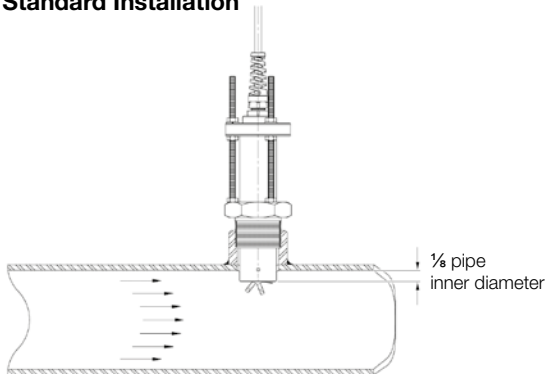

**Installation Straight Piping Requirements**

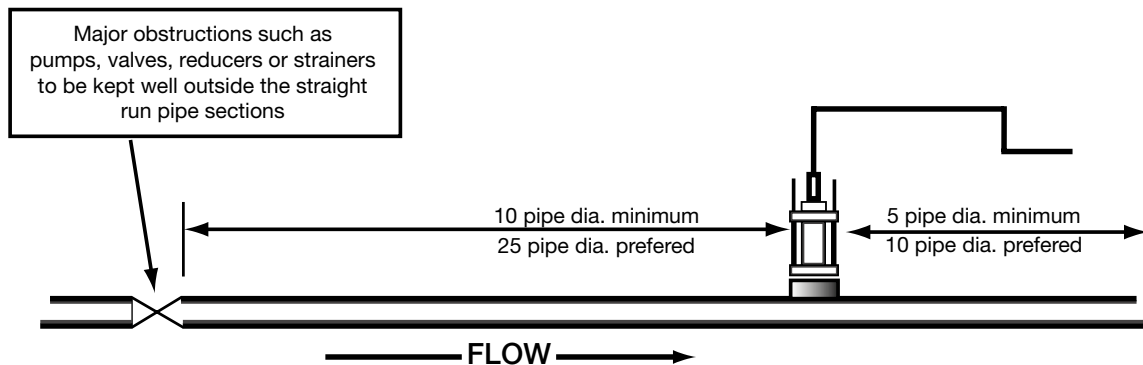



Dimensions (in mm)

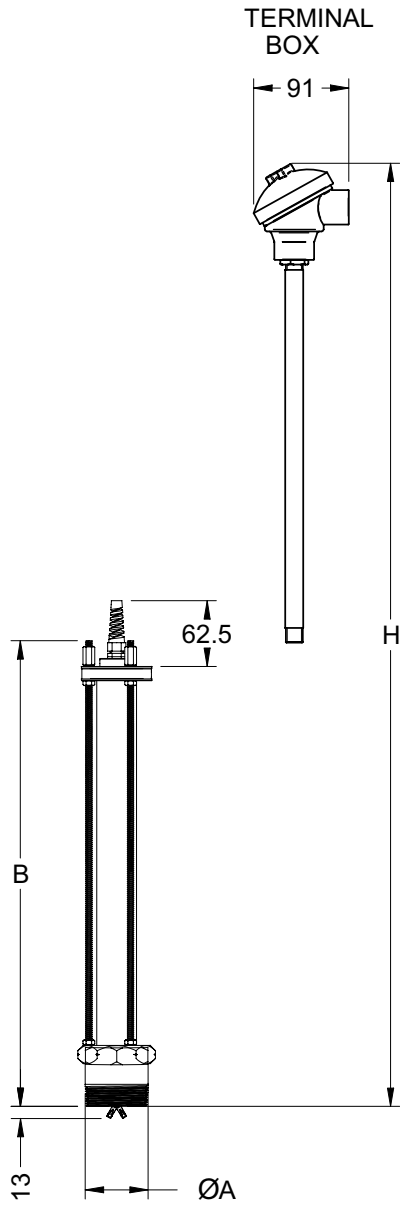

All dimensions in mm,  $\pm 2$  mm

	DOR-42	DOR-52
$\text{ØA}$	1 1/2" or 2" NPT/R2	2" NPT/R2
$B$	198	444
Configuration	$H$	$H$
Terminal box	385	869