



## Air velocity sensor

duct sensor for air velocity measurement in HVAC-systems



measuring  
•  
monitoring  
•  
analysing

KAH

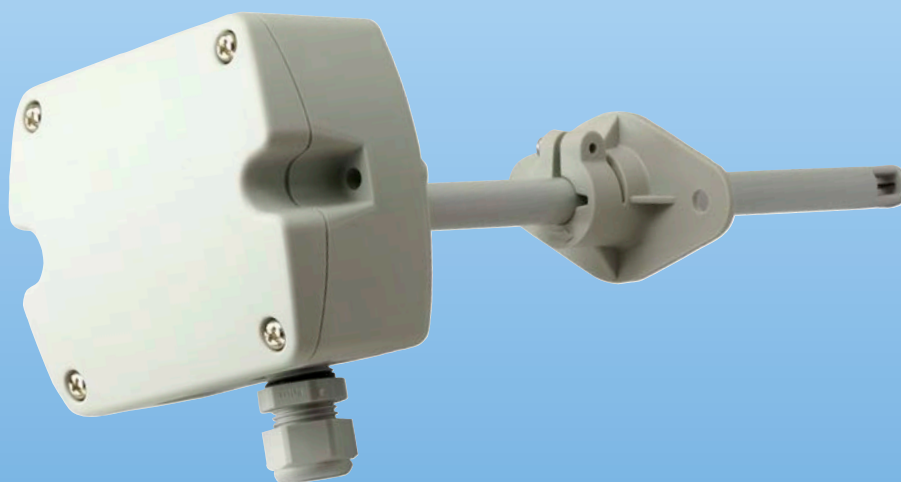

- Selectable working range air: 0 ... 10/15/20 m/s
- Output signal: 0 ... 10 V<sub>DC</sub> or 4 ... 20 mA
- Supply voltage: 24 V<sub>AC/DC</sub>
- Low angular dependence



SS

KOBOLD companies worldwide:

AUSTRALIA, AUSTRIA, BELGIUM, BULGARIA, CANADA, CHINA, CZECHIA, EGYPT, FRANCE, GERMANY, GREAT BRITAIN, HUNGARY, INDIA, INDONESIA, ITALY, MALAYSIA, MEXICO, NETHERLANDS, PERU, POLAND, REPUBLIC OF KOREA, ROMANIA, RUSSIA, SPAIN, SWITZERLAND, THAILAND, TUNISIA, TURKEY, USA, VIETNAM

KOBOLD Messring GmbH  
Nordring 22-24  
D-65719 Hofheim/Ts.  
Head Office:  
+49(0)6192 299-0  
+49(0)6192 23398  
info.de@kobold.com  
www.kobold.com



### Description

KAH air velocity transmitters are ideal for accurate ventilation control applications. They are operating on an innovative hot film anemometer principle.

The thin film sensor guarantees very good accuracy at low air velocity, which is not possible for conventional anemometers with commercial temperature sensors or NTC bead thermistors.

Moreover, the sensor is much more insensitive to dust and dirt than all other anemometer principles. This means high reliability and low maintenance costs. The configuration equipment allows air velocity adjustment of the sensor.

### Selectable Working Range

The measuring range and the response time can be selected with jumpers by the user. This facilitates easy adjustment to the correct working range on start-up.

### Mounting

Using the mounting device the penetration depth is infinitely adjustable.

**Note:** The sensor is to be mounted so that the direction of air-flow is parallel to the sensor duct.

### Applications

- HVAC applications
- Process and environmental control

### Advantages

- Adjustable damping time
- Short reaction time
- Adjustable probe insertion length
- Low angular dependence
- Easy installation
- Adjustable to application requirements

### Technical Details

#### Measuring values

Working range <sup>1)</sup> :	0 ... 10 m/s (0 ... 2000 ft/min) 0 ... 15 m/s (0 ... 3000 ft/min) 0 ... 20 m/s (0 ... 4000 ft/min)
Output signal <sup>1)</sup> :	0 ... 10 V -1mA < I <sub>L</sub> < 1mA 0 ... 10 m/s/0 ... 15 m/s/0 ... 20 m/s: 4 - 20 mA R <sub>L</sub> < 450 Ω
Accuracy at 20 °C (68 °F), 45 % rH, 1013 hPa:	0.2 ... 10 m/s (40 ... 2000 ft/min) ± (0.2 m/s + 3 % of reading) 0.2 ... 15 m/s (40 ... 3000 ft/min) ± (0.2 m/s + 3 % of reading) 0.2 ... 20 m/s (40 ... 4000 ft/min) ± (0.2 m/s + 3 % of reading)
Response time τ <sub>90</sub> <sup>1)2)</sup> :	typ. 4 s or typ. 1 s (at constant temperature)
Probe length:	200 mm (can vary)
Power supply:	24 V <sub>AC/DC</sub> ± 20 %
Current consumption for AC supply:	max. 170 mA
for DC supply:	max. 70 mA
Angular dependence:	< 3 % of reading at   Δα   < 10°
Connection:	screw terminals up to 1.5 mm <sup>2</sup> (AWG 16)
Cable gland:	M16x1.5
Electromagnetic compatibility:	EN 61326-1 EN 61326-2-3
Housing material:	polycarbonate, UL94V-0 approved
Protection:	IP 65
Operating pressure:	max. 200 mbarg
Temperature range Working temperature probe:	-25 ... +50 °C (-13 ... 122 °F)
Working temperature electronic:	-10 ... +50 °C (-14 ... 122 °F)
Storage temperature:	-30 ... +60 °C (-22 ... 140 °F)
Working range humidity:	5 ... 95 % rH (non-condensing)

<sup>1)</sup> Selectable by jumper

<sup>2)</sup> Response time τ<sub>90</sub> is measured from the beginning of a step change of air velocity to the moment of reaching 90% of the step.

**Dimensions [mm]**

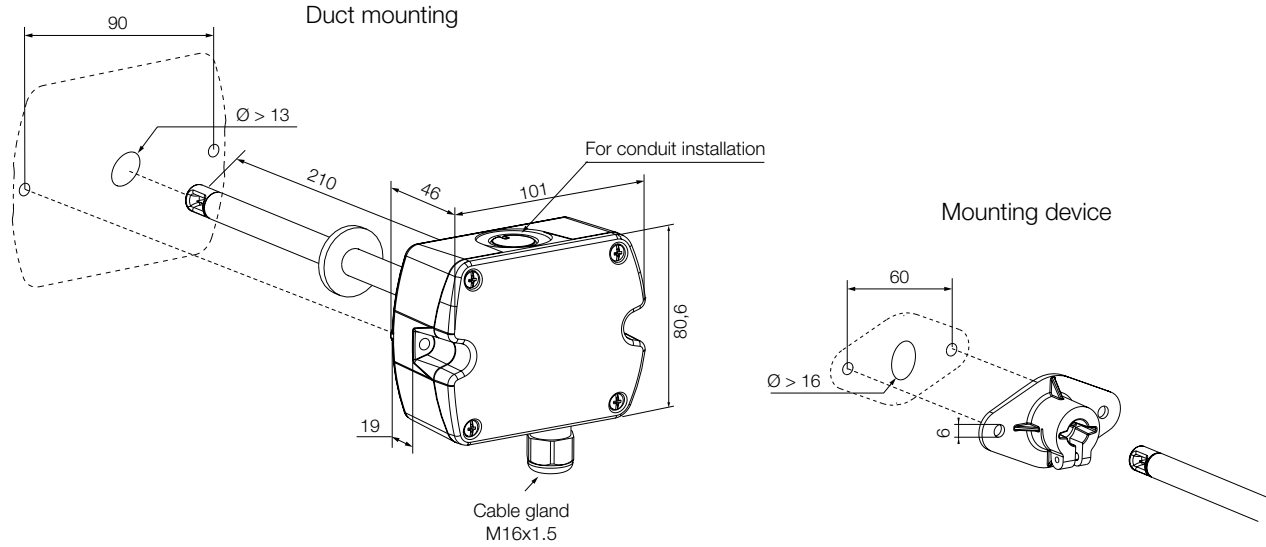

**Wiring settings**

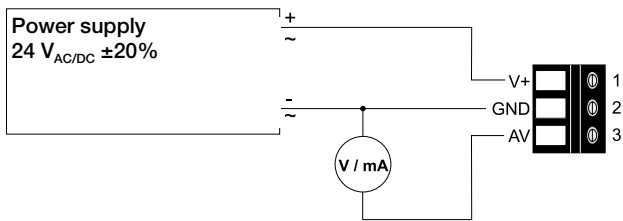

V+ = Supply voltage  
GND = Ground  
AV = Airflow output

**Selection of output signal**

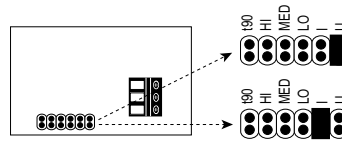

Jumper Voltage (U)  
= factory setting

Jumper Current (I)

**Selection of working range**

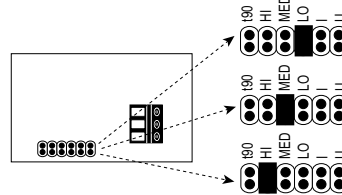

Jumper 0...10 m/s

Jumper 0...15 m/s

Jumper 0...20 m/s  
= factory setting

**Selection of response time**

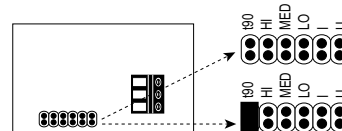

No jumper FAST approx. 1 s

Jumper SLOW approx. 4 s  
= factory setting

The output signal, working range and response time are selected via the jumpers according to the picture.

**Order Details** (Example: KAH 2 2 00 4)

Model	Thread	Sensor length	Cable length	Output/display
<b>KAH-</b> Air velocity sensor	<b>2</b> = compact for duct mounting	<b>2</b> = 200 mm	<b>00</b> = without cable	<b>4</b> = 0 - 10 V, 4 - 20 mA/ without display