

GIM600R - 2-dimensional

 2-dimensional, measuring range up to $\pm 90^\circ$

CANopen® / SAE J1939

Overview

- Designed for Mobile Maschines
- E1 compliant design
- Load dump protection
- Protection up to IP 69K
- Corrosion protection CX (C5-M)
- Connection cable / cable with M12 connector
- Interface CANopen® / SAE J1939
- Redundant versions (2-channel architecture)
- Applicable up to PLd (ISO 13849)



Picture similar

Technical data

Technical data - electrical ratings

Voltage supply	8...36 VDC
Reverse polarity protection	Yes
Short-circuit proof	Yes
Consumption typ.	15 mA (24 VDC, w/o load) 30 mA (24 VDC, w/o load, redundant)
Initializing time typ.	≤ 1 s after power on
Interface	CANopen® SAE J1939
Measuring range	$\pm 90^\circ$
Resolution	1 ... 0.001 ° CANopen® 0.01 ° SAE J1939
Accuracy (+25 °C)	Typ. $\pm 0.1^\circ$
Repeatability typ.	0.025 ° (+25 °C)
Absolute accuracy max. (horizontal)	$\pm 0.24^\circ$ (+25 °C) $\pm 0.41^\circ$ (0...+50 °C) (measuring range $\pm 10^\circ$, see general information)
"Absolute accuracy max. (vertical)	$\pm 0.47^\circ$ (+25 °C) $\pm 0.86^\circ$ (0...+50 °C) (measuring range $\pm 10^\circ$, see general information)
Cross-axis-sensitivity max. (+25 °C)	$\pm 0.23^\circ$ (2-dimensional horizontal) $\pm 0.47^\circ$ (2-dimensional vertical) Measuring range $\pm 10^\circ$
Sensing method	MEMS technology
Sensing rate	1000 Hz (1 ms)
Limit frequency	0.1...30 Hz, 2. order / low-pass filter
Output stages	CAN-Bus compatible ISO 11898
Load dump protection	ISO 16750-2 for 12 V/24 V systems Pulse 5b (test criteria B)

Technical data - electrical ratings

Interference immunity	EN 61000-6-2 ISO 7637-2* ISO 7637-3* ISO 11452-2* ISO 11452-4* ISO 11452-5* EN 61000-4-2 (CD ± 8 kV, AD ± 15 kV) * Severity level according to ECE R10 (Rev. 6 + Amd 02:2021-12)
Emitted interference	EN 61000-6-3 EN 61000-6-4 ISO 7637-2* CISPR 25:2008 (30...1000 MHz) * Severity level according to ECE R10 (Rev. 6 + Amd 02:2021-12)
MTTF _d (ISO 13849)	High (>100 years) Use in safety functions exclusively based on quick start guide, Application Note and MTTF _d reliability prediction (request separately).
Programmable parameters	Preset / zero position Resolution Limit frequency (low-pass filter) Rotating direction
Diagnostic function	Supply voltage monitoring Temperature control
Approval	UL approval / E217823

Technical data - mechanical design

Dimensions W x H x L	72 x 24 x 64 mm
Protection EN 60529	IP 66 IP 67 IP 68 (without connector) IP 69K (without connector)
Material	Housing: polyamide (glass fiber reinforced) Base plate: metal

GIM600R - 2-dimensional

2-dimensional, measuring range up to $\pm 90^\circ$

CANopen® / SAE J1939

Technical data

Technical data - mechanical design

Corrosion protection	IEC 60068-2-52 Salt mist for ambient conditions CX (C5-M) according to ISO 12944-2
Operating temperature	-40...+85 °C (see general information)
Resistance	EN 60068-2-6 Vibration 30 g, 60-2000 Hz EN 60068-2-27 Shock 200 g, 3 ms EN 60068-2-64 Random vibration 10 grms, 20-1000 Hz

Technical data - mechanical design

Temperature changes	EN 60068-2-14, -40...+85 °C
Weight approx.	150 g
Connection	Flylead connector M12, 5-pin, length 300 mm

Optional

- 3-axis acceleration PDO mappable (see general information)
- GIM140R-compatible SDO baud rate table
- With integrated terminating resistor

GIM600R - 2-dimensional

2-dimensional, measuring range up to $\pm 90^\circ$

CANopen® / SAE J1939

General information

For a precise thermal design, the self-heating of the inclination sensor must be taken into account depending on the mounting and ambient conditions as well as the electronics and supply voltage. As an approximation, 5 K self-heating applies when the sensor is mounted on a painted metal base. If the inclination sensor is operated close to the maximum characteristic values, the actual temperature at the housing of the inclination sensor must be measured. The specified transverse sensitivity applies to reference mounting. Electromagnetic influences can lead to reduced measuring accuracy (see application note). Reference the zero position of the inclination sensor after installation. Regularly check the zero point stability of the inclination sensor when installed. Acceleration values (optional) are for information purposes only. Further information on request.

Installation position



Horizontal installation

When installing the 2-dimensional inclination sensor with the housing in horizontal position, make sure the base plate is aligned parallel to the horizontal line.

The X and Y axes of the sensor can each be inclined relative to the horizontal plane, which corresponds to a rotation about the other axis. There is one measured value supplied for each axis. Sensor default is 2-dimensional measuring within the selected range, e.g. $\pm 30^\circ$. Zero-crossing is exactly in the horizontal line.

Inclination angle 0°
X-axis, Slope long



Inclination angle $+30^\circ$
X-axis, Slope long

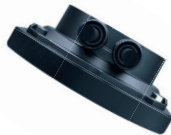

Inclination angle 0°
Y-axis, Slope lateral



Inclination angle -30°
Y-axis, Slope lateral

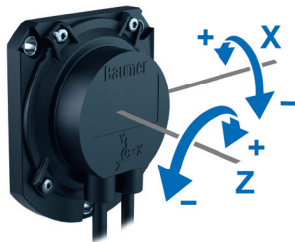
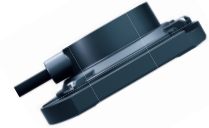

Vertical installation

When installing the 2-dimensional inclination sensor with the housing in vertical position, make sure the base plate is aligned parallel to the vertical line. The X and Y axes of the sensor can each be inclined relative to the horizontal plane, which corresponds to a rotation about the other axis. There is one measured value supplied for each axis.

Sensor default is 2-dimensional measuring within the selected range, e.g. $\pm 30^\circ$. Zero-crossing is exactly in the vertical line.

Inclination angle 0°
X-axis, Slope long



Inclination angle $+30^\circ$
X-axis, Slope long



Inclination angle 0°
Z-axis, Slope lateral



Inclination angle $+30^\circ$
Z-axis, Slope lateral

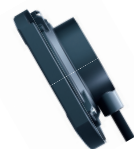

GIM600R - 2-dimensional

 2-dimensional, measuring range up to $\pm 90^\circ$

CANopen® / SAE J1939

Terminal assignment

Flylead connector M12, 5-pin

Pin	Assignment	Description
1	CAN_GND	Ground connection relating to CAN
2	+Vs	Voltage supply
3	GND	Ground connection relating to +Vs
4	CAN_H	CAN Bus Signal (dominant High)
5	CAN_L	CAN Bus Signal (dominant Low)

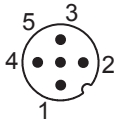

M12-1

 M12 flange connector (male),
 A-encoding

Flylead connector 2xM12, 5-pin (Bus-in/Bus-out)

Pin	Assignment	Description
1	CAN_GND	Ground connection relating to CAN
2	+Vs	Voltage supply
3	GND	Ground connection relating to +Vs
4	CAN_H	CAN Bus Signal (dominant High)
5	CAN_L	CAN Bus Signal (dominant Low)

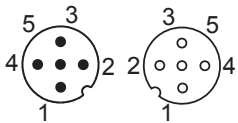

M12-1

M12-2

 M12 flange connector (male/female),
 A-encoding

Flylead connector 2xM12, 5-pin (2x Bus-in)

Pin	Assignment	Description
1	CAN_GND	Ground connection relating to CAN
2	+Vs	Voltage supply
3	GND	Ground connection relating to +Vs
4	CAN_H	CAN Bus Signal (dominant High)
5	CAN_L	CAN Bus Signal (dominant Low)

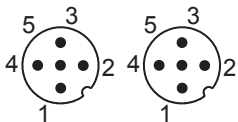

M12-1

M12-2

 M12 flange connector (2x male),
 A-encoding

For all connection types

Terminals GND and CAN_GND are internally connected and identical in their functions. Max. load on the terminals Vs and GND is 1.5 A each. Daisy chain current max. 1.5 A.

GIM600R - 2-dimensional

 2-dimensional, measuring range up to $\pm 90^\circ$

CANopen® / SAE J1939

CANopen® features

Device profile	CANopen® CiA DS 301 V4.2 Inclinometer profile DS 410 V2.0 LSS service profile DS 305 V3.0
Default	Resolution 0.1° Limit frequency 5 Hz Baud rate 250 kbit/s Node-ID 1 Node-ID 2 (redundant version) Time-driven: 100 ms

SAE J1939 features

Default	Resolution 0.01° Limit frequency 5 Hz Transmission rate 250 kbit/s Address: 247, 248 (redundant version)
---------	---

Data transfer

CANopen - PDO Mapping / Node-ID 1 / PDO 1

LSB	MSB	LSB	MSB	LSB	MSB
Byte 0	1	2	3	4	5
Temperature	Inclination angle X-axis Slope long = 0 ► $\pm 90^\circ$ in steps of 0.1° Increasing angle with clockwise rotation		Inclination angle Y-/Z-axis Slope lateral = 0 ► $\pm 90^\circ$ in steps of 0.1° Increasing angle with clockwise rotation		

CANopen - PDO Mapping / Node-ID 2 / PDO 1

LSB	MSB	LSB	MSB	LSB	MSB
Byte 0	1	2	3	4	5
Temperature	Inclination angle X-axis Slope long = 0 ► $\pm 90^\circ$ in steps of 0.1° Increasing angle with clockwise rotation		Inclination angle Y-/Z-axis Slope lateral = 0 ► $\pm 90^\circ$ in steps of 0.1° Increasing angle with clockwise rotation		

Data transfer

SAE J1939 - PGN 65363: 2-dimensional device message

LSB	MSB	LSB	MSB	LSB	MSB	LSB	MSB
Byte 1	2	3	4	5	6	7	8
X-axis signed word tilt reading (resolution 0.01°)		Y-/Z-axis signed word tilt reading (resolution 0.01°)		Temp. signed byte (°C)	Module ID	Error ID	

Data length:	8 bytes
Extended data page:	0
Data page:	0
PF:	255 (Prop. B)
PS:	83
Priority:	6
PG number:	65363 (00FF53h)

Description of data payload:

- Byte 1: X-axis signed word LSB tilt reading (resolution 0.01°)
- Byte 2: X-axis signed word MSB tilt reading (resolution 0.01°)
- Byte 3: Y-/Z-axis signed word LSB tilt reading (resolution 0.01°)
- Byte 4: Y-/Z-axis signed word MSB tilt reading (resolution 0.01°)
- Byte 5: Device temperature signed byte (resolution 1 °C)
- Byte 6: Module ID
- Byte 7,8: Error ID

GIM600R - 2-dimensional

2-dimensional, measuring range up to $\pm 90^\circ$

CANopen® / SAE J1939

Dimensions

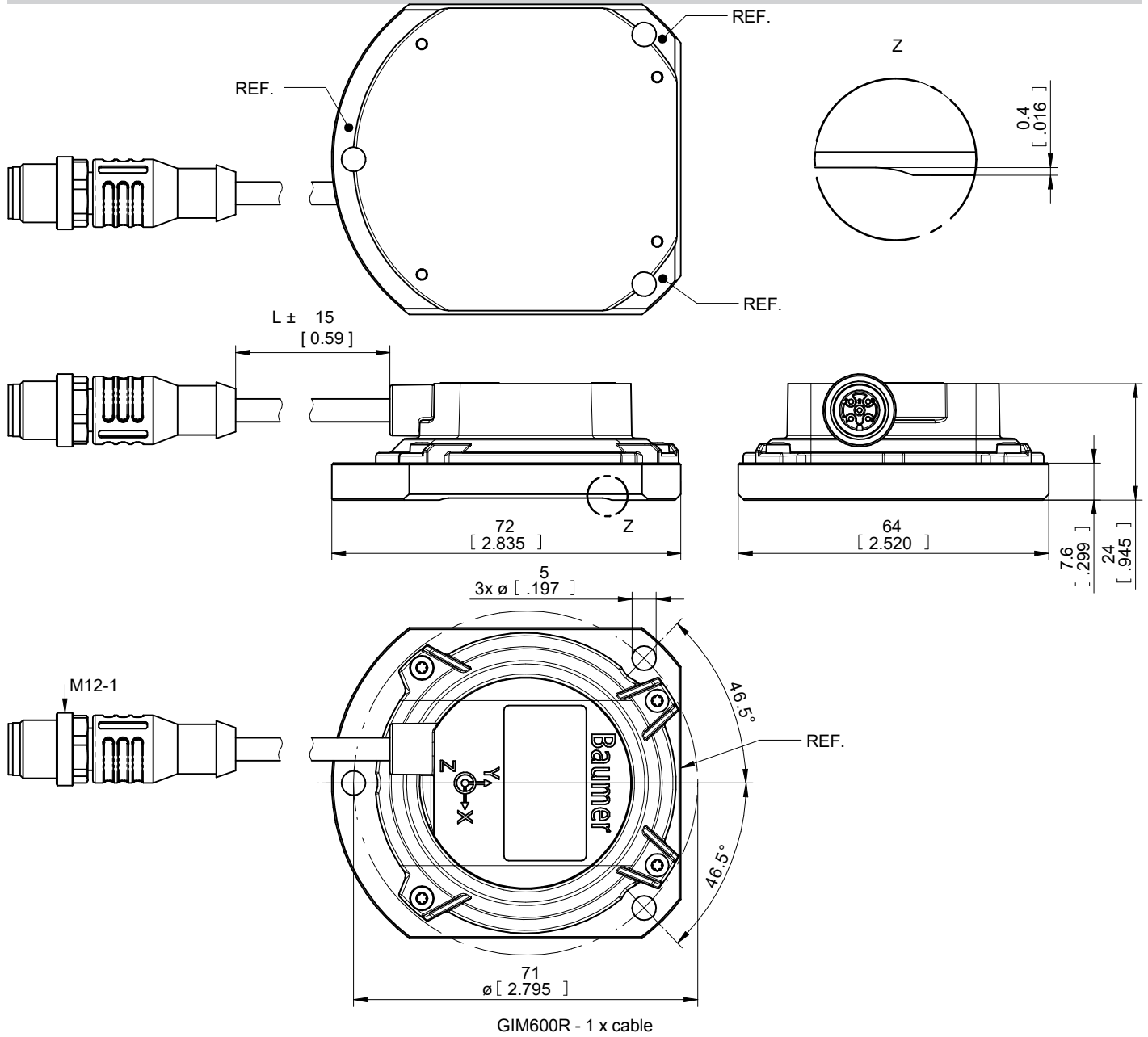

GIM600R - 2-dimensional

2-dimensional, measuring range up to $\pm 90^\circ$

CANopen® / SAE J1939

Dimensions

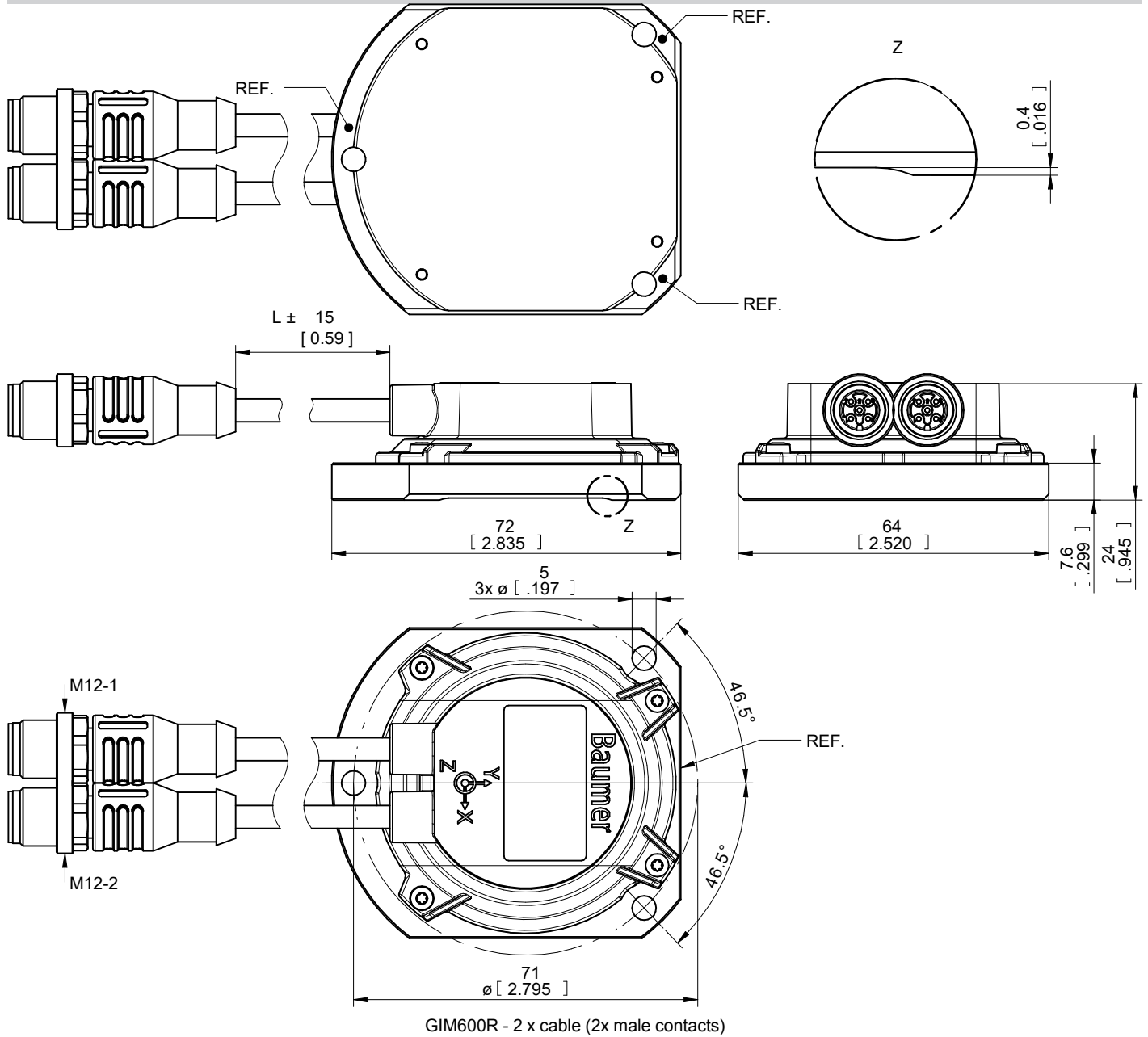

GIM600R - 2-dimensional

2-dimensional, measuring range up to $\pm 90^\circ$

CANopen® / SAE J1939

Dimensions

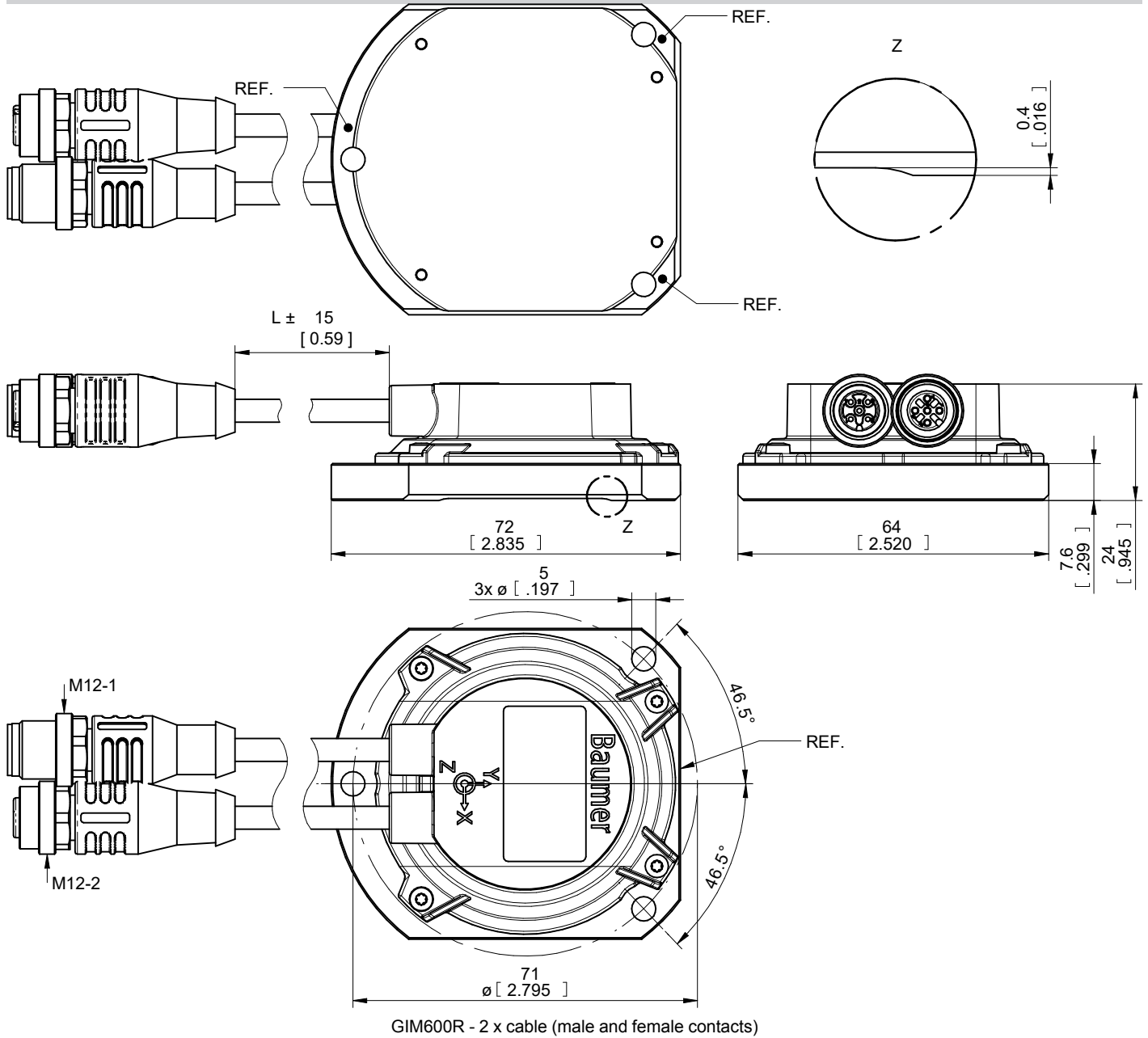

GIM600R - 2-dimensional

2-dimensional, measuring range up to $\pm 90^\circ$

CANopen® / SAE J1939

Dimensions

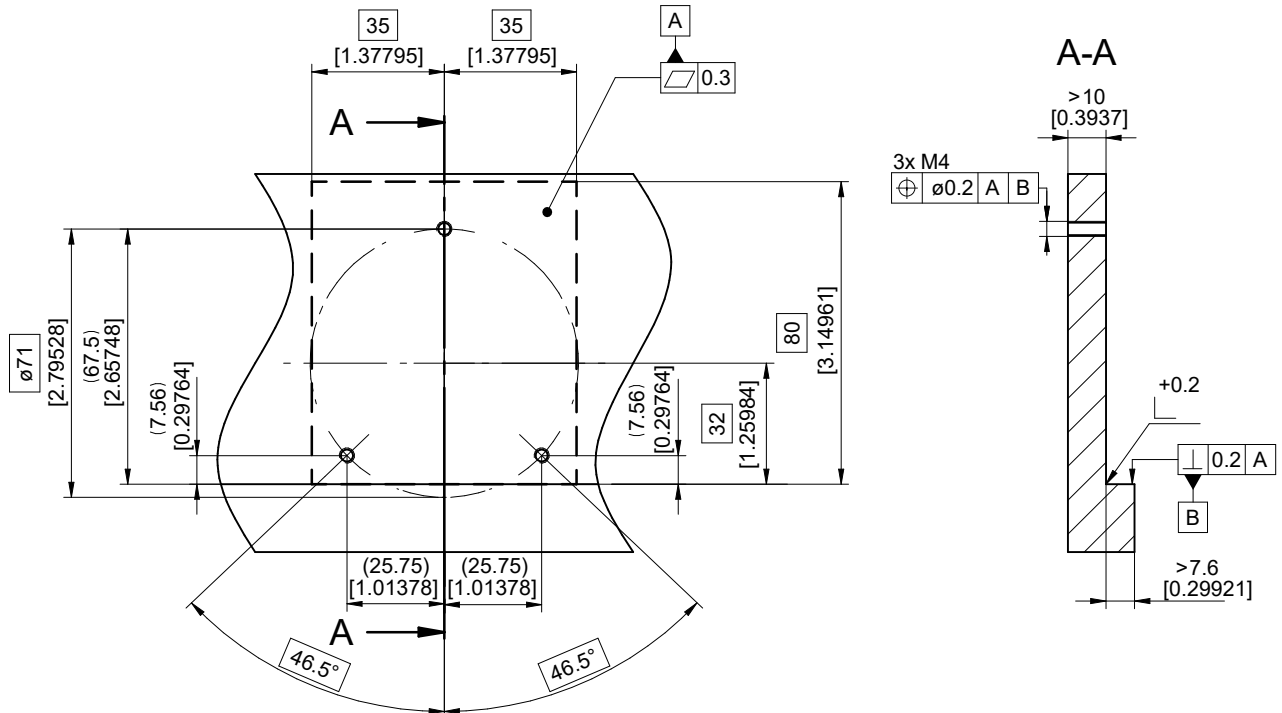

GIM600R - Drilling pattern / mounting plate

GIM600R - 2-dimensional

 2-dimensional, measuring range up to $\pm 90^\circ$

CANopen® / SAE J1939

Ordering reference

	GIM600R	-	N	#	90	.	#	##	.	A	/
Product	GIM600R										
Housing	Plastic reinforced / base plate metal		N								
Number of axes	2-dimensional, housing horizontal			2							
	2-dimensional, housing vertical ⁽²⁾			V							
Measuring range	$\pm 90^\circ$				90						
Connection⁽¹⁾	Cable 0.3 m with M12, 5-pin, male contacts									S	
	2x cable 0.3 m with M12, 5-pin, male and female contacts (Bus-in/Bus-out)									P	
	2x cable 0.3 m with M12, 5-pin, 2x male contacts (2x Bus-in)									R	
Voltage supply / interface	8...36 VDC / CANopen® (1-channel)										C6
	8...36 VDC / CANopen® redundant (2-channel design)										C8
	8...36 VDC / SAE J1939 (1-channel)										C9
	8...36 VDC / SAE J1939 redundant (2-channel design)										CR
Operating temperature	-40...+85 °C										A
Option	Without option										

(1) Other connection types on request

(2) On request